



**2009-2014 Aprilia RSV4 FACTORY / RSV4R
Z-Fi TC / Z-Fi QS INSTALLATION INSTRUCTIONS
P/N T940**

WARNING!

USE ONLY IN RACE OR OTHER CLOSED COURSE APPLICATIONS AND NEVER ON PUBLIC ROADS

Z-Fi products do not meet California CARB highway requirements

**Z-Fi TC/QS CONTROL UNIT
FUEL HARNESS
COIL HARNESS
SHIFT SWITCH & MOUNTING HARDWARE
DOWNLOAD Z-FI MAPPER SOFTWARE & ITS INSTRUCTIONS FROM WEBSITE
USB CABLE
SCOTCHLOK
SWINGARM STICKERS
O2 ELIMINATOR**

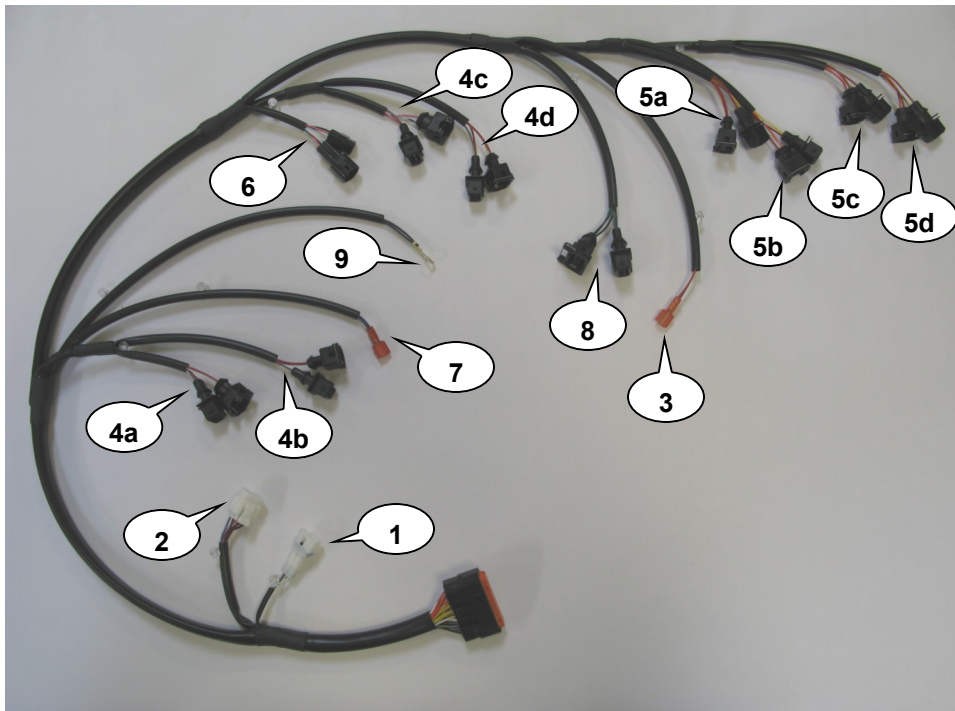

- (1) MAP SELECT
- (2) ZAFM CONNECTOR
- (3) SWITCHED POWER (RED TAG)
- (4a) PRIMARY INJECTOR CONNECTORS
FRONT CYLINDER #2
- (4b) PRIMARY INJECTOR CONNECTORS
FRONT CYLINDER #4
- (4c) PRIMARY INJECTOR CONNECTORS
REAR CYLINDER #1
- (4d) PRIMARY INJECTOR CONNECTORS
REAR CYLINDER #3
- (5a) SECONDARY INJECTOR CONNECTORS
REAR CYLINDER #3
- (5b) SECONDARY INJECTOR CONNECTORS
REAR CYLINDER #1
- (5c) SECONDARY INJECTOR CONNECTORS
FRONT CYLINDER #4
- (5d) SECONDARY INJECTOR CONNECTORS
FRONT CYLINDER #2
- (6) GEAR POSITION SENSOR
- (7) THROTTLE POSITION SENSOR
- (8) CRANK POSITION SENSOR
- (9) GROUND LUG

***Read through all instructions before beginning installation. This is not a replacement for the ECU.
This document is intended for use by qualified technicians. For more specific stock component identification and
location information refer to a factory service manual.***

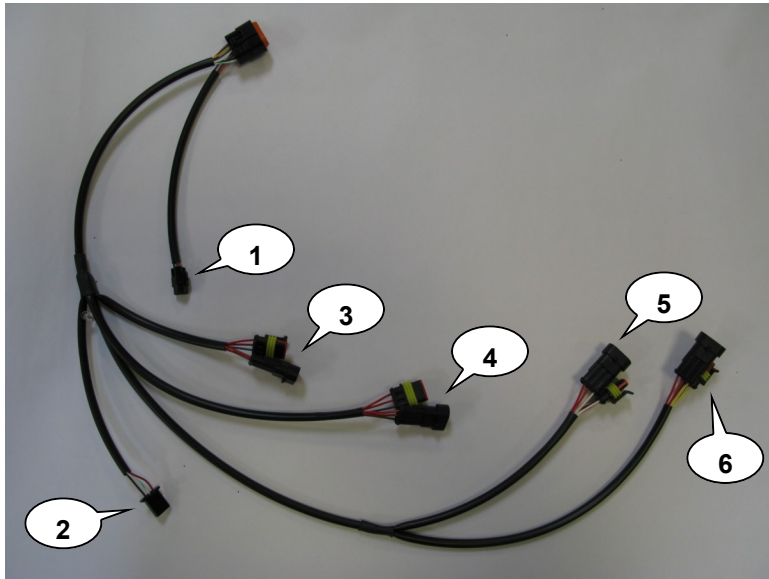

Coil Harness:

- (1) TC adjust switch connection (n/a for Z-Fi QS)
- (2) Shift switch connection
- (3) Coil Cylinder #2
- (4) Coil Cylinder #4
- (5) Coil Cylinder #1
- (6) Coil Cylinder #3

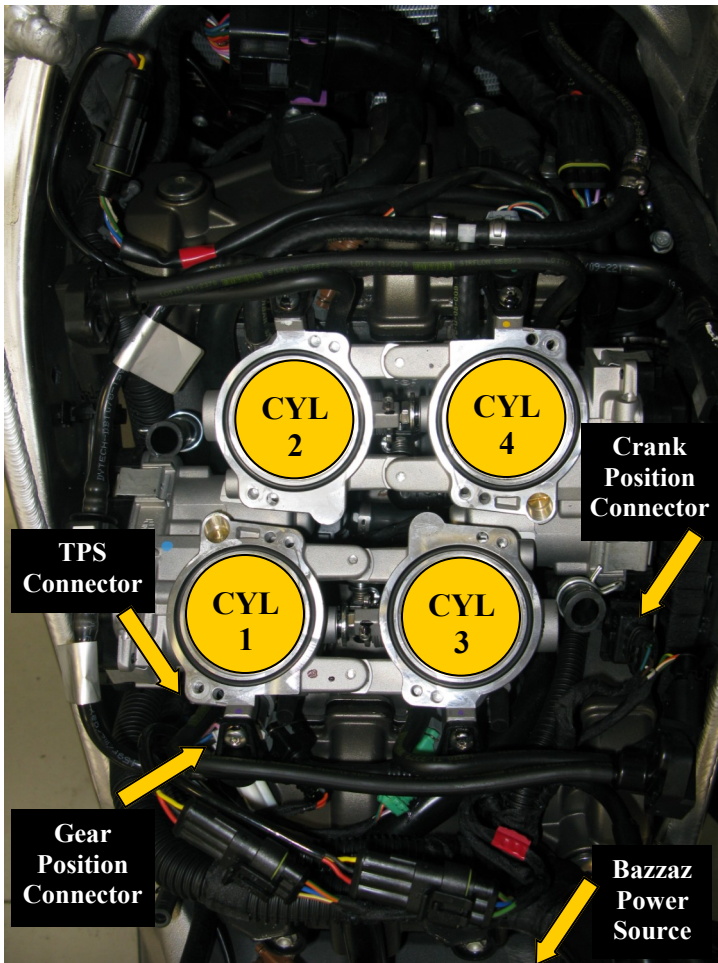

Cylinder and component identification

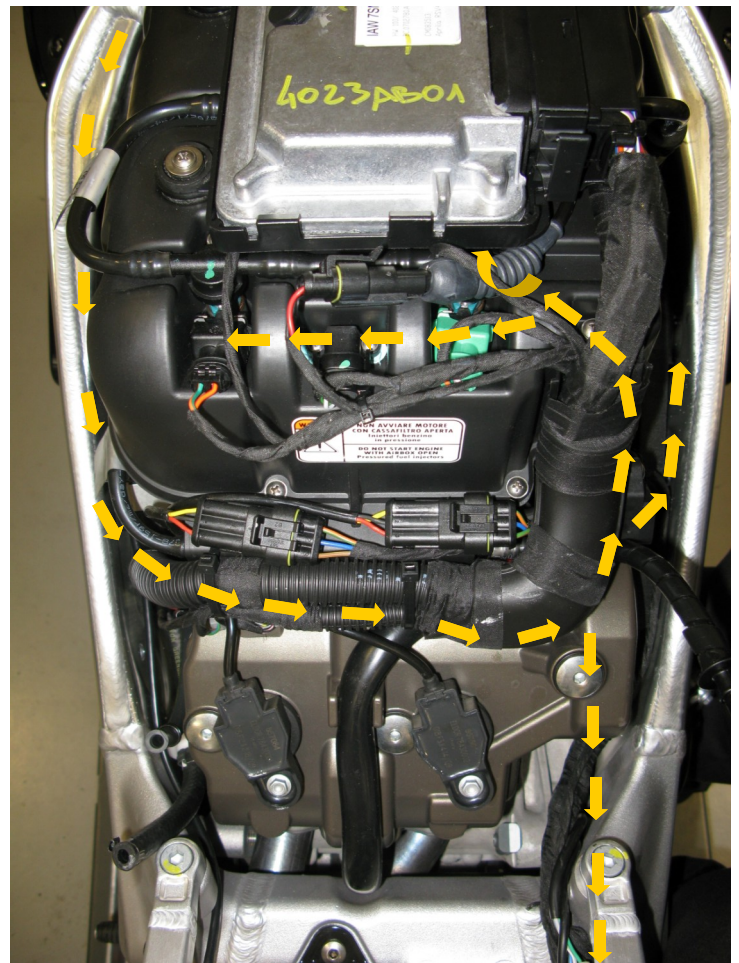

Recommended Bazzaz harness routing shown with yellow arrows

**WE STRONGLY SUGGEST THAT AN EXPERIENCED TECHNICIAN
INSTALL THIS BAZZAZ PRODUCT**

1. Remove following components: Seat, fuel tank, left side fairing, air box.
2. Locate the throttle control unit, found bolted to the front left frame spar near the radiator. Remove the mounting hardware and install the Bazzaz control unit mounting bracket over the throttle control unit. Secure by reinstalling the existing hardware. Attach supplied velcro to the back side of the control unit and also the mounting bracket to secure the control unit within the mounting bracket. (Photo 1)



Photo 1

3. To properly route the harness and gain access to coil and injector connectors for the front two cylinders the air box must be removed. See your service manual for air box removal instructions. Once the air box has been removed route the Bazzaz harness through the engine compartment in front of the engine down to the control unit mounted in the bracket on the frame. Connect the harness to the control unit, and secure the harness using supplied cable ties. Be sure to secure the harness away from any hot or moving components that may cause damage to the harness. (Photo 2)

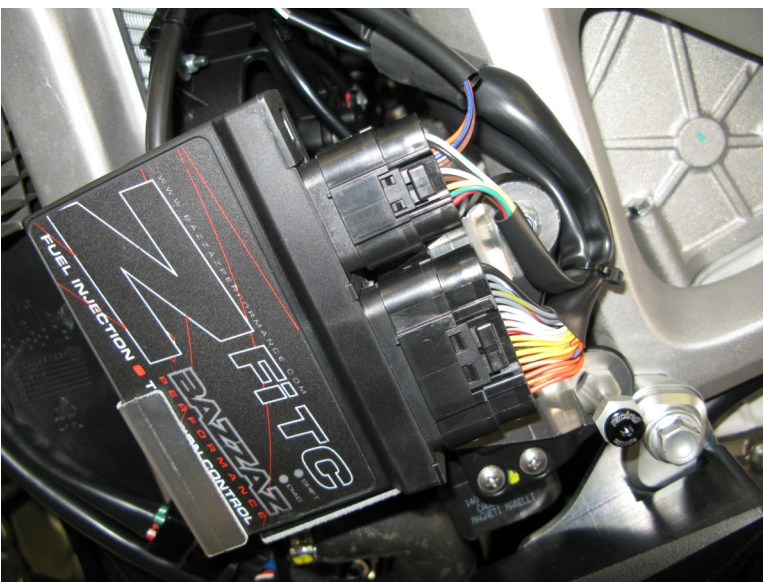

Photo 2

4. Route the remaining harness inside of the left frame spar. With the air box removed, connect the Bazzaz harness inline with the corresponding injectors and / or coils for the front two cylinders. Once these connections have been made, secure the harness routing neatly with cable ties and reinstall the air box. (Photo 3)

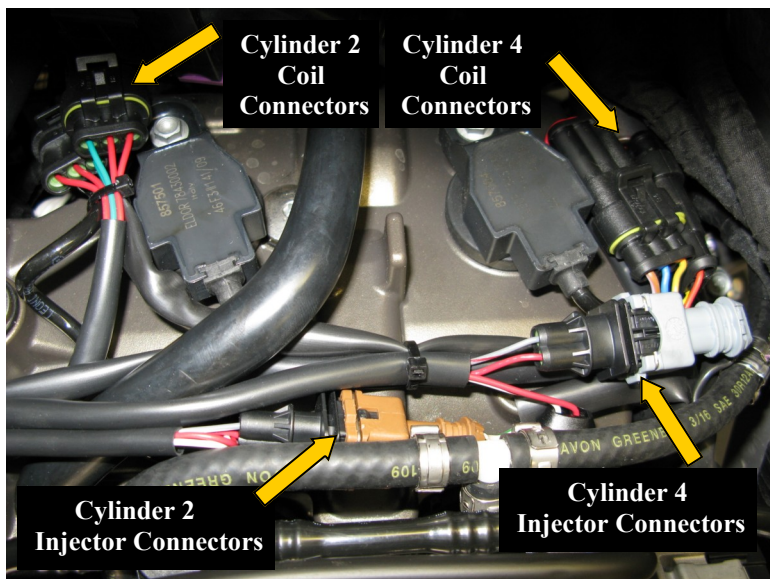

Photo 3

WARNING! Make sure that the pins in the connectors of the Bazzaz harness are properly aligned with those of the stock harness connectors.

5. Following the flow of the harness from the front of the bike to the rear, next connect the Bazzaz harness to the Throttle Position Sensor (TPS). This connector is located under the rear cylinder throttle bodies on the left side of the bike, behind the throttle valve actuator motor. Disconnect this connector in order to gain access to its wires in the rear of the connector. Locate the yellow/black wire (pin #1) and using the supplied scotchlok connector in the Bazzaz kit, crimp onto this wire. Next insert the T-Tap connector attached to the blue wire of the Bazzaz harness. Now reconnect stock TPS connector. (Photos 4 and 5)

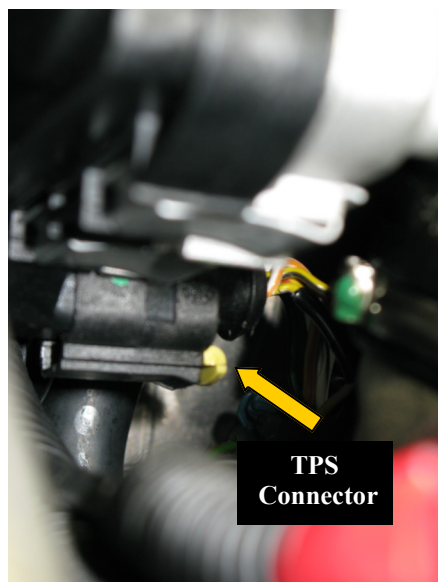

Photo 4

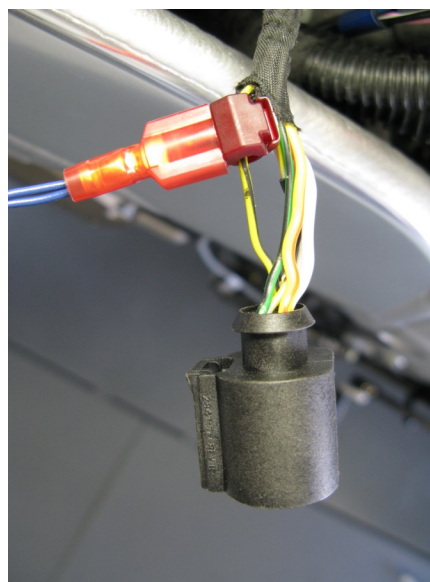
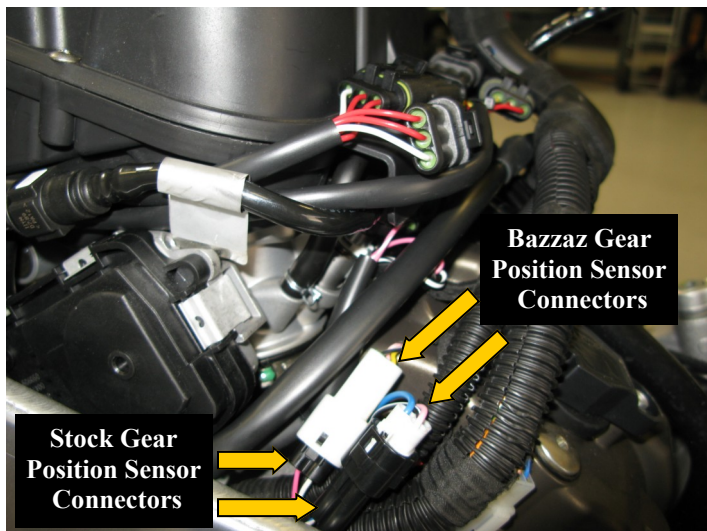

Photo 5

Stock harness throttle position connector installed

6. Locate the Gear Position Sensor connectors found between the left side frame spar and the left rear cylinder head. Connect the mating Bazzaz connectors inline with the sensor and stock harness connectors. (Photo 6)



WARNING! Make sure that the pins in the connectors of the Bazzaz harness are properly aligned with those of the stock harness connectors.

Photo 6

7. Remove the countershaft sprocket cover. Disconnect the existing O2 sensor from the harness. This sensor will no longer be used; the wires should be neatly secured away from any moving components, or the sensor may be removed and the remaining port / bung in the exhaust can then be plugged. Next, connect the Bazzaz O2 eliminator supplied with the kit in place of this sensor and secure it to the same location made available due to the removal of the sensor connector. The O2 eliminator requires an external ground source through the use of a ground lug. Attach the O2 eliminator ground lug to the stock wire routing bracket using the existing hardware. (Photo 7)

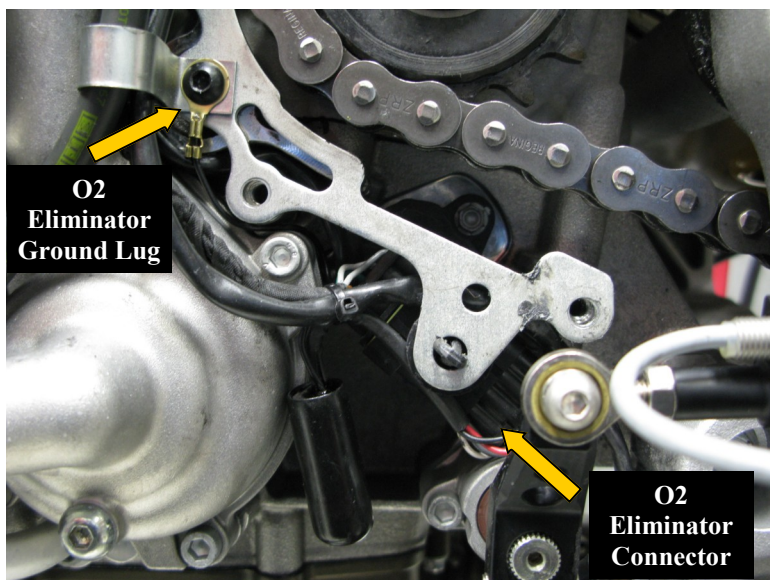

Photo 7

8. While working on the left side of the bike, route the ground lug lead of the Bazzaz harness between the frame and engine and connect it to the countershaft sprocket cover using the existing mounting hardware. **Note: Any solid chassis ground may be used for mounting the ground lug.** (Photo 8)

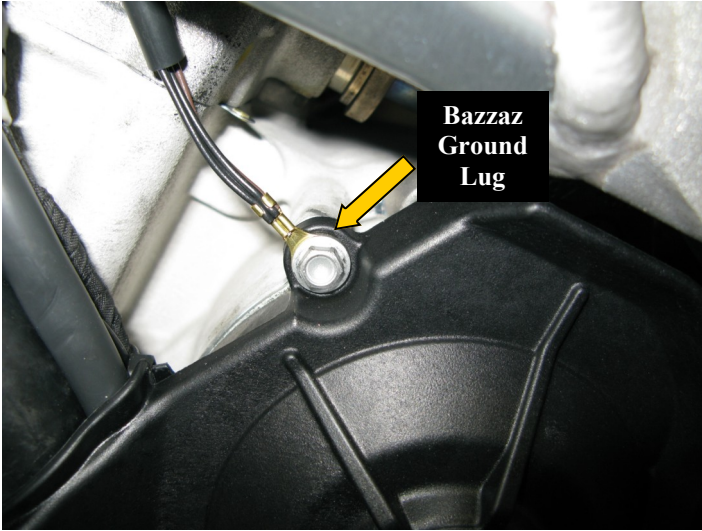

Photo 8

9. Connect the mating Bazzaz connectors inline with the rear cylinder lower injectors and coils. At this stage of the installation the air box may be reinstalled. (Photo 9 & 10)

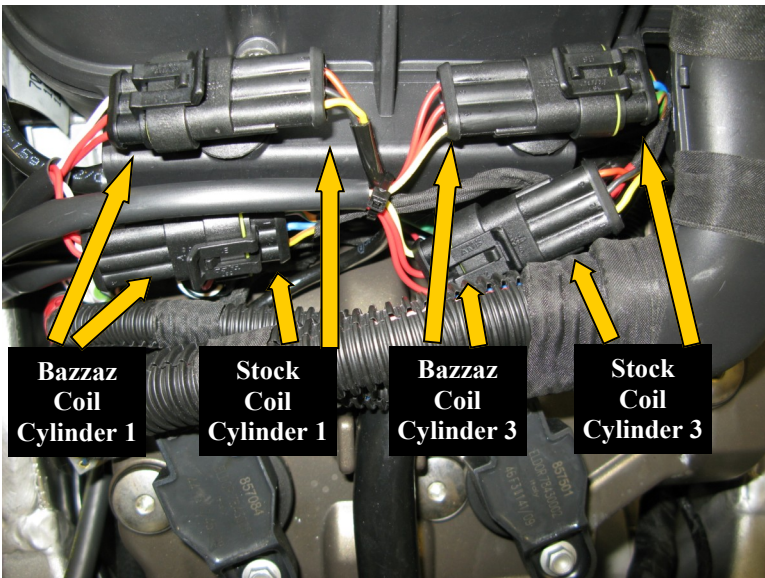

Photo 9

WARNING! Make sure that the pins in the connectors of the Bazzaz harness are properly aligned with those of the stock harness connectors.

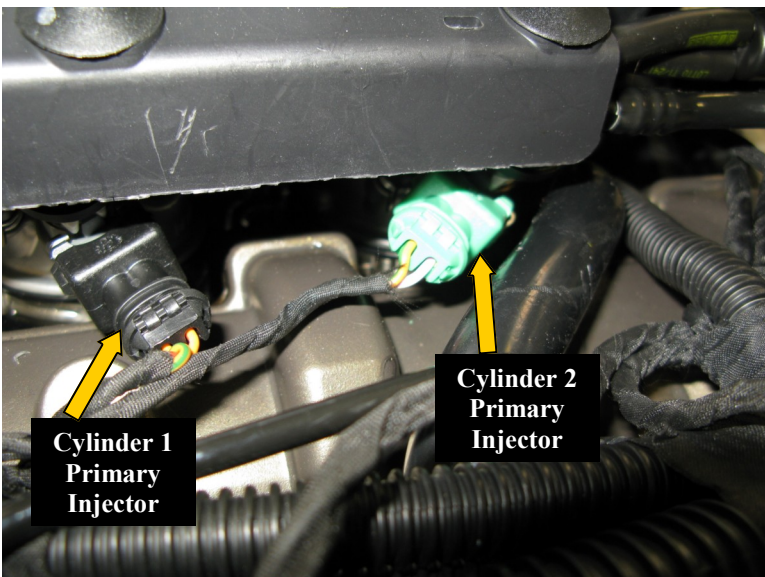

Photo 10

10. Now on the right side of the bike locate the speed sensor connector, located just inside the right side sub frame rail under the fuel tank. Using the supplied scotchlok connector, crimp onto the green wire. This connection will supply the Bazzaz system with switched 12 volts. Insert the T-Tap connector on the Bazzaz harness with the red wire attached. (Photo 11)

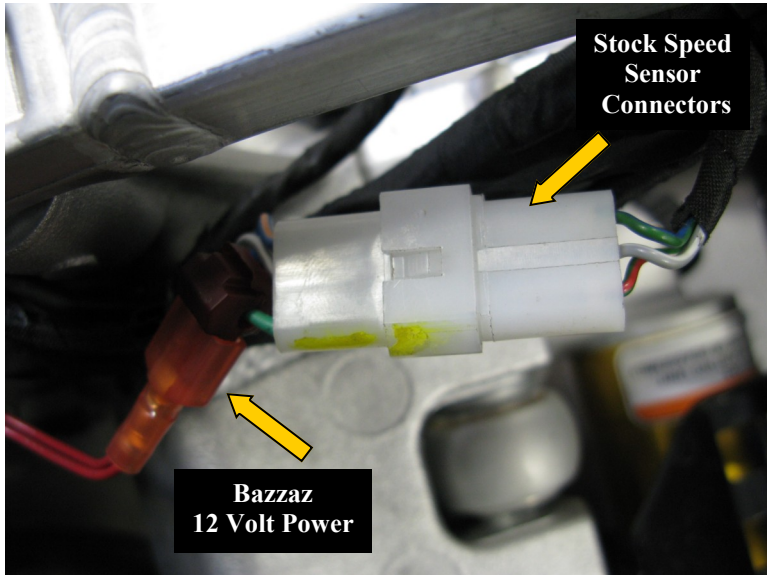

Photo 11

11. Connect the mating Bazzaz connectors inline with the Crank Position Sensor (CPS) and stock harness connectors. These connectors can be found between the engine and the right frame spar. (Photo 12)

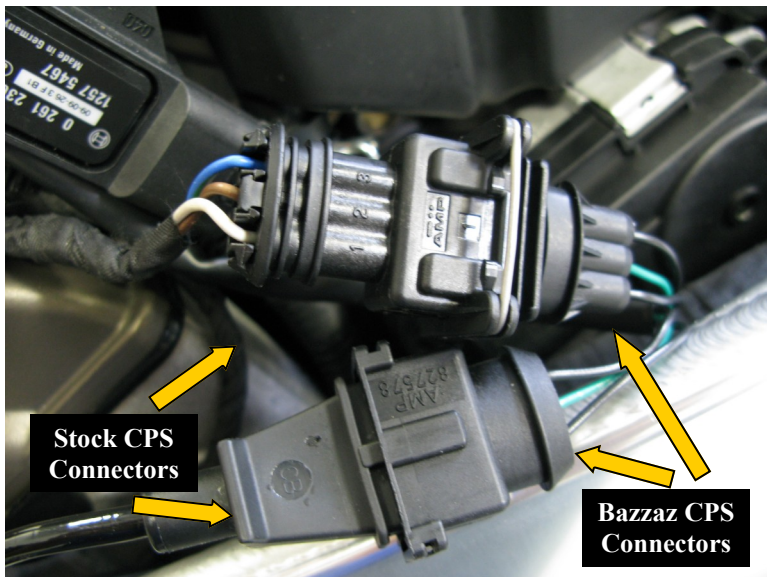

Photo 12

WARNING! Make sure that the pins in the connectors of the Bazzaz harness are properly aligned with those of the stock harness connectors.

12. Route the remaining Bazzaz harness up the right side of the air box, along with the stock wiring harness. Connect the corresponding Bazzaz connectors inline with the secondary injectors for all four cylinders. (Photo 13)

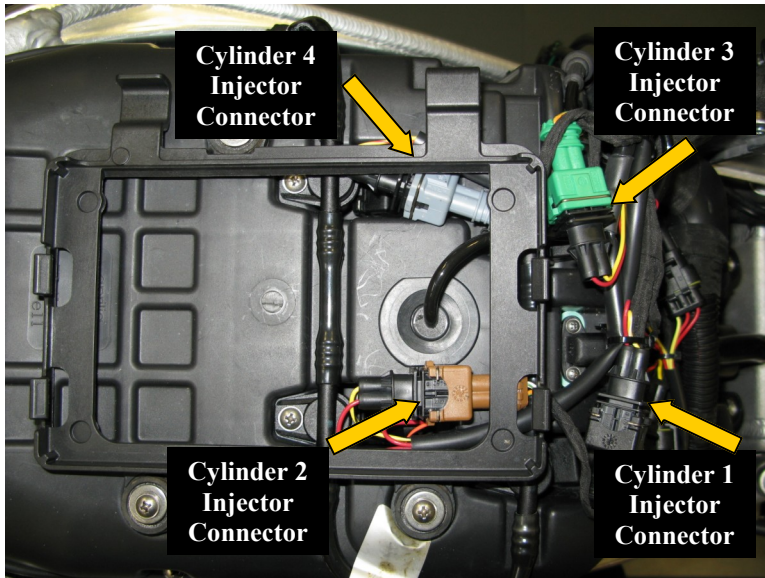

Photo 13

WARNING! Make sure that the pins in the connectors of the Bazzaz harness are properly aligned with those of the stock harness connectors.

13. The stock gear lever is not equipped with a shift linkage / rod. This requires the use of after market rear sets in order to mount the Bazzaz shift switch for this application. (Photo 14)

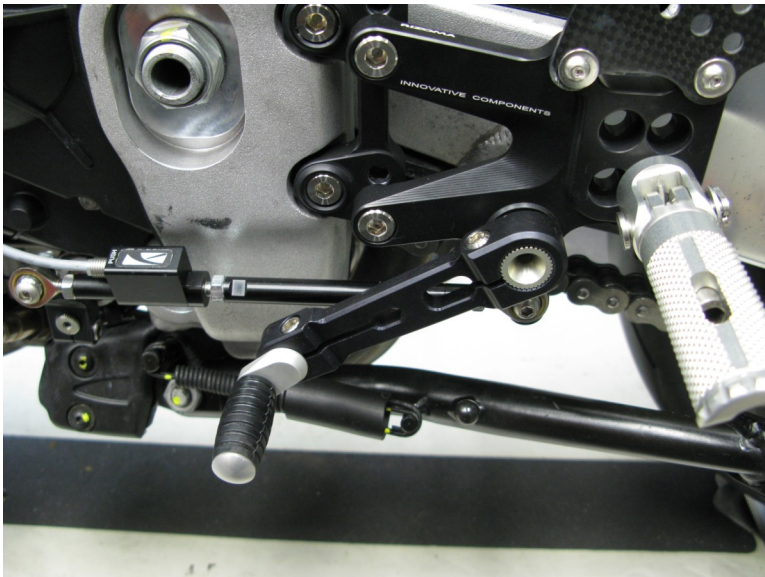

Photo 14

- A) Remove the stock shift rod.
- B) In place of the stock rod, install the Bazzaz shift switch on the front shift linkage.
- C) Install the supplied replacement shift rod by screwing it into place between the Bazzaz shift switch and rear shift linkage.
- D) Secure components by tightening 10mm nuts.
- E) Route shift switch sensor cable into engine compartment and connect it with mating connector on the Bazzaz coil harness. Secure shift switch cable away from any moving components as damage to the cable may cause shift switch sensor failure.

14. The installation of the Bazzaz EMS system is now complete. Secure the harness with cable ties.

Note: Space for additional components and wiring is minimal and routing the harness as close as possible to that of the stock harness will make the reinstallation of the fuel tank much simpler. Care should be taken when reinstalling the fuel tank as not to damage any components or connectors.

Reinstall fuel tank and start bike to verify proper installation and system functionality. If any problem is found, please carefully follow through the installation steps again. If problem still persists, please call Bazzaz tech support department at (909) 597-8300. After it is determined that everything is correct reinstall the components removed in step 1.

The Bazzaz Z-Fi controller is capable of storing two maps. These maps can be selected through the use of a map select switch which can be mounted on the handlebar for easy access and can be purchased separately. Or these maps can be selected by connecting or disconnecting the map select jumper supplied with kit. When the map select jumper is connected the control unit is operating using map 1 (photo 15). When the map select jumper is disconnected the control unit is operating using map 2. (Photo 16).

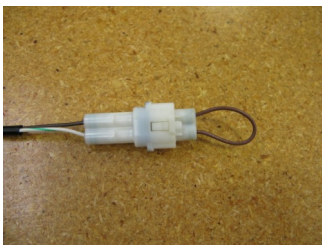

Photo 15

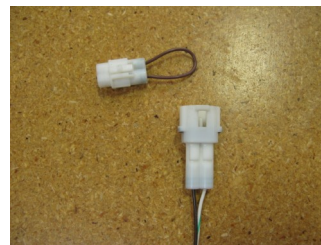

Photo 16

*** To create the ideal map(s) we recommend using the optional Z-AFM self-tuning module. ***