



## 2011 KX250F Z-Fi MX

### INSTALLATION INSTRUCTIONS

P/N F430

#### **WARNING!**

USE ONLY IN RACE OR OTHER CLOSED COURSE APPLICATIONS AND NEVER ON PUBLIC ROADS

#### PARTS LIST:

Z-Fi MX Control Unit

Fuel Harness

DOWNLOAD Z-FI MAPPER SOFTWARE & ITS INSTRUCTIONS FROM WEBSITE

USB Cable

Z-Fi MX aluminum bracket

Velcro

Bazzaz stickers

Cable ties

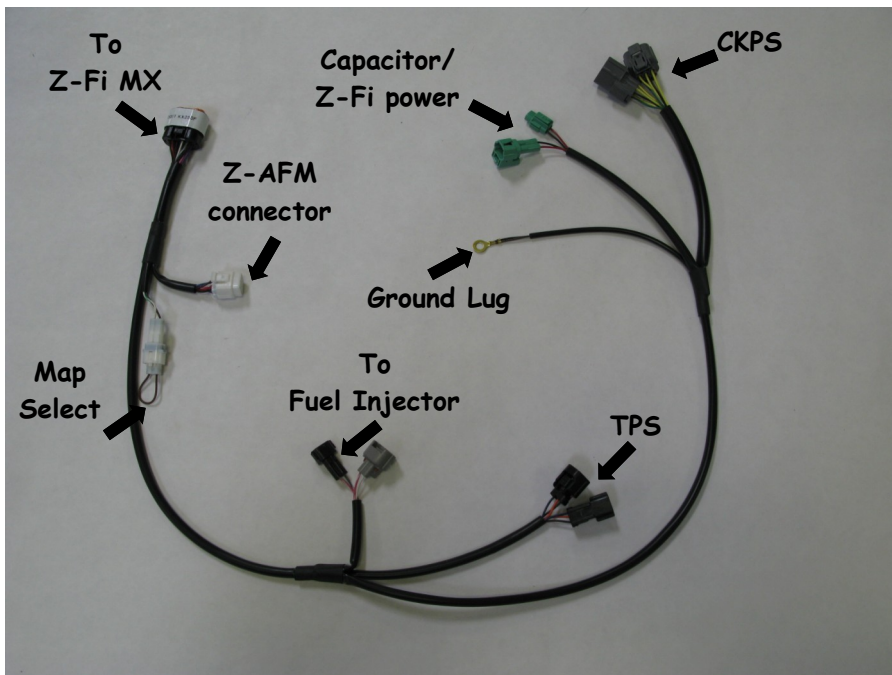

*Read through all instructions before beginning installation.*

*This is not a replacement for the ECU.*

**WE STRONGLY SUGGEST THAT AN EXPERIENCED TECHNICIAN  
INSTALL THIS BAZZAZ PRODUCT**

*When routing the Z-Fi MX harness it is best to choose a routing path similar to that of the OEM harness. The Bazzaz harness is designed with lengths that allow for multiple scenarios, dependent of the installers individuals needs. **IMPORTANT:** Always secure harness clear of all moving components and the exhaust system. As contact with these components can result in damage to the harness.*

1. Remove the seat, left and right side covers, and fuel tank. Refer to factory service manual.
2. Locate the fuel injector (photo 1), disconnect the factory connector and connect the Z-Fi harness in-line with the fuel injector and factory connector. (Photo 2)

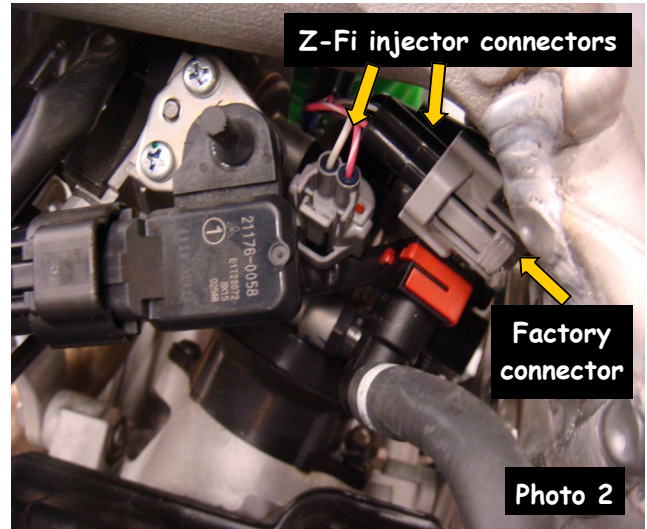
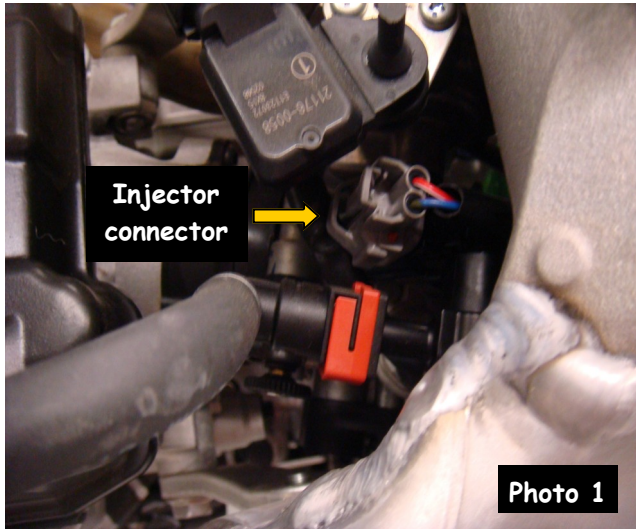

3. Locate the throttle position sensor found on the left side of throttle body assembly (photo 3). Disconnect the factory TPS connector and connect the Z-Fi harness in-line with the TPS sensor and factory connector. (Photo 4)

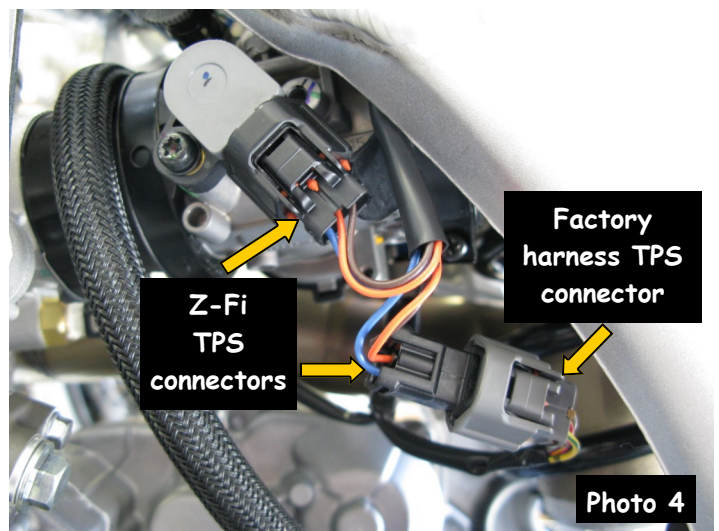
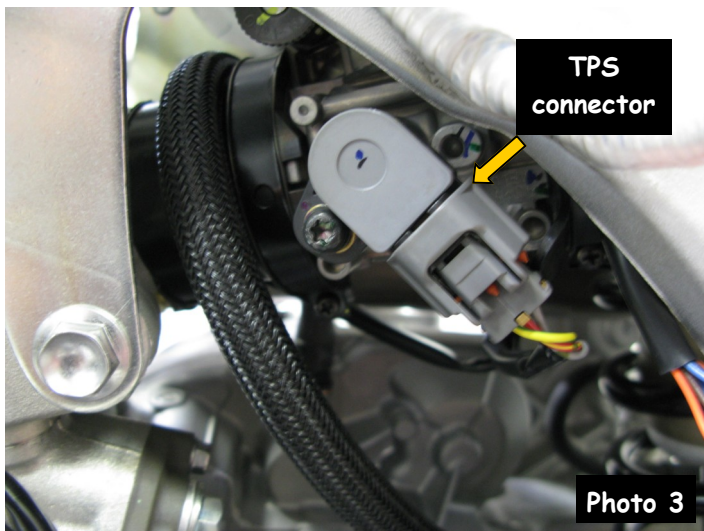

4. Route the Z-Fi harness forward following the factory harness routing. (Photo 5) Use supplied cable ties to secure the Z-Fi harness when routing.

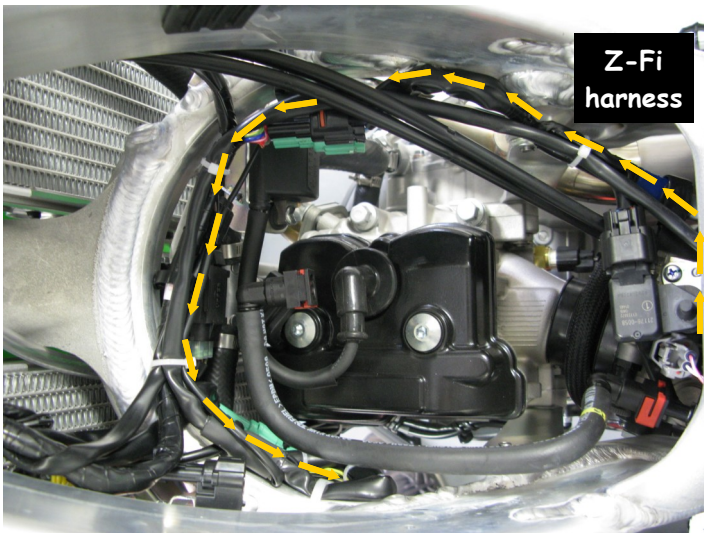
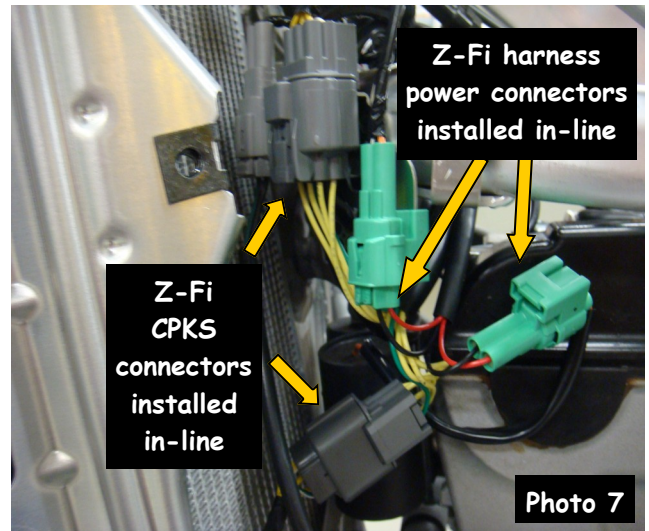
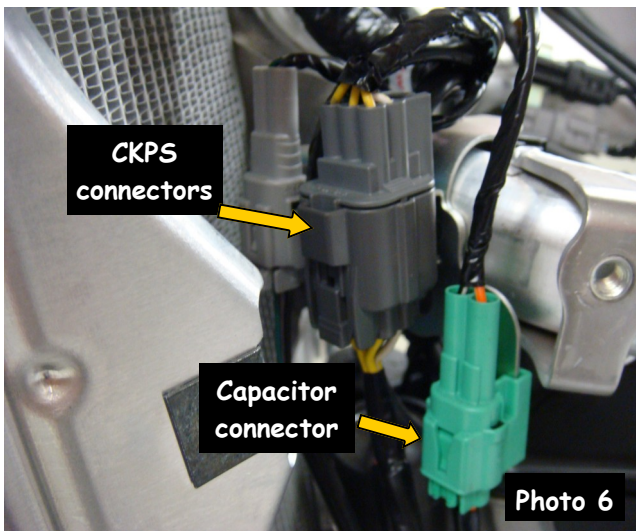

Photo 5

5. Locate the Crank Position Sensor (CKPS) connectors (2 gray six pin connectors) toward the front left of the frame (photo 6). Disconnect the factory CKPS sensor connectors and connect the Z-Fi harness inline with the factory connectors. (Photo 7)



6. Locate the capacitor connectors, 2 green two pin connectors next to the CKPS connectors left of the frame (photo 6). Disconnect the factory capacitor connectors and connect the Z-Fi (capacitor/power) connectors in-line. (Photo 7)

7. Attach the Z-Fi harness ground wire to the motorcycles coil chassis ground. (Photo 8)

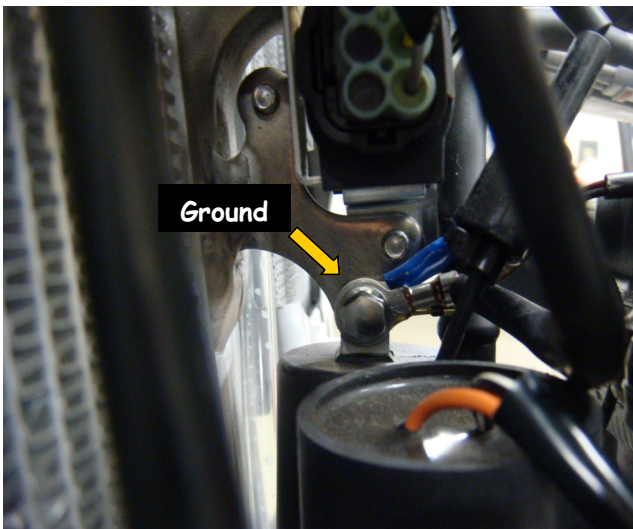

8. Raise the subframe (see service manual) and route the Z-Fi harness back through the plastic protector and into the airbox. (Photo 9)

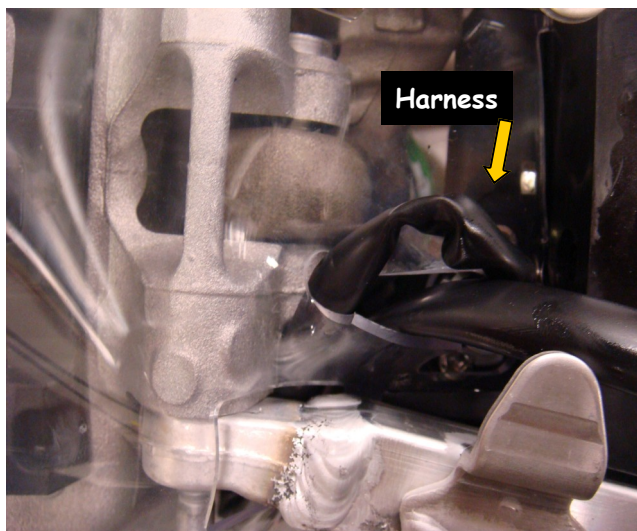

Photo 9

9. Lower and re-attach the subframe (see service manual).

10. Attach supplied velcro adhesive to Z-Fi bracket and back of the Z-Fi. Connect the black Z-Fi harness connector into the Z-Fi. (Photo 10)

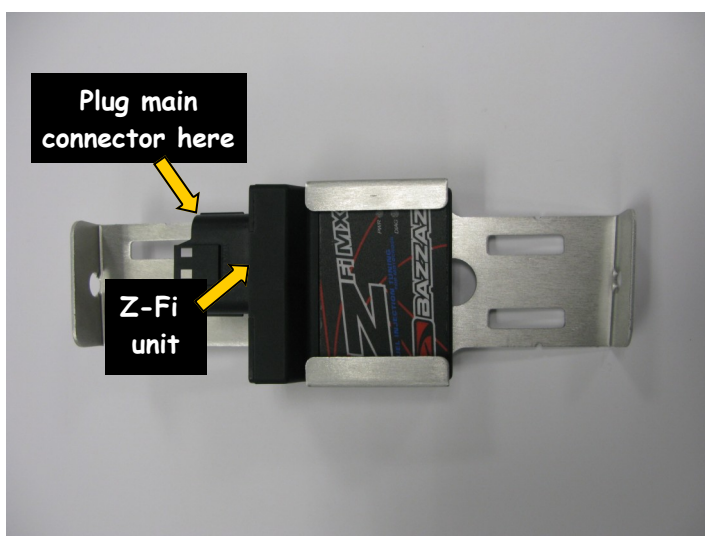

Photo 10

11. Attach the Z-Fi bracket to the subframe using the cable ties provided. (Photo 11)

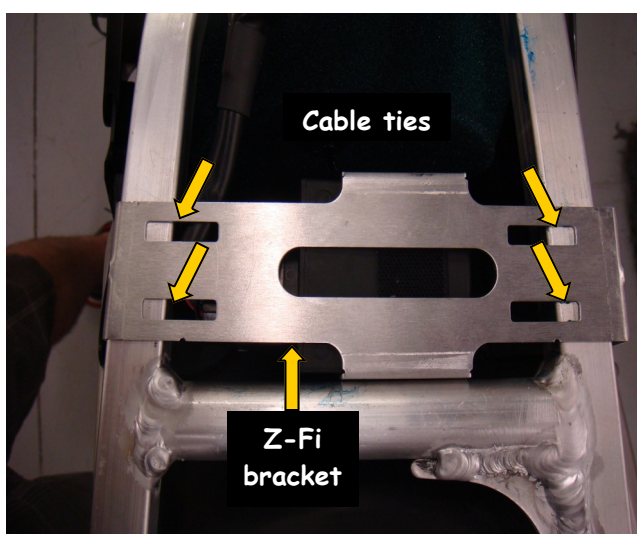
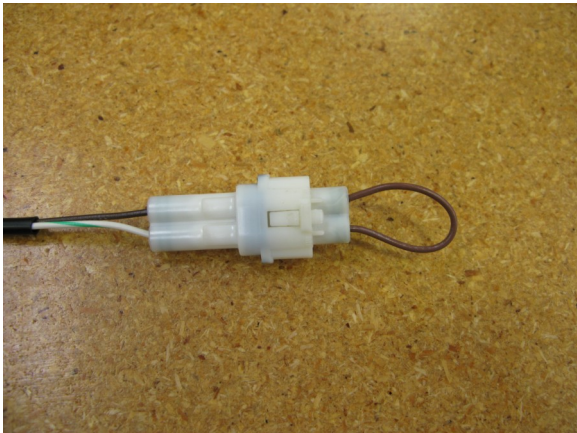

Photo 11

12. Check that all wiring connections are tight.
13. Re-install fuel tank, left and right side panels, and seat. Check that wiring is not pinched or kinked.
14. If any problem is found, please carefully follow through the installation steps again. If problem still persists, please call Bazzaz tech support department at (909) 597-8300.

The Bazzaz Z-Fi MX controller is capable of storing two maps. These maps can be selected through the use of a map select switch which can be mounted on the handlebar for easy access and can be purchased separately. Or these maps can be selected by connecting or disconnecting the map select jumper supplied with kit. When the map select jumper is connected the control unit is operating using map 1. When the map select jumper is disconnected the control unit is operating using map 2.



**Map 1**

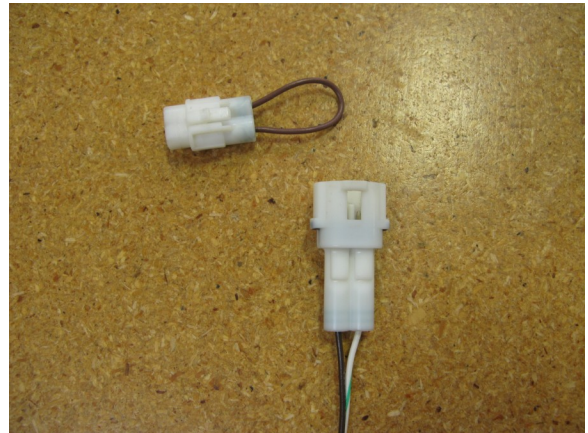

**Map 2**

**\* To create the ideal map(s) we recommend using the optional Z-AFM self-tuning module. \***